

Selas Fuel Trains

The Selas Fuel Train is engineered to distribute fuel to the burner safely; each Fuel Train is custom designed per customers' needs/wants. Ideal for any oven burner, gas burner, nozzle mix burner, or premix burner (may require additional equipment). Fuel Trains come painted in safety yellow and can operate with natural gas or propane. Contact the factory to learn how Selas can custom build a Fuel Train for your combustion needs.

Description

There are various builds for the Selas Fuel Train based on the customer's request. The traditional Fuel Train consists of the following to maintain and stop gas flow:

- Inlet Ball Valve
- Drip Leg
- Inlet Pressure Gauge with Ball Valve
- Y Gas Strainer
- Pressure Reducing Regulator
- Double Shut-Off Valve with leak test ports and visual indication proof of closure switch
- Low/High Gas Pressure Switches
- Outlet Pressure Gauge with Ball Valve

Applications

- Any oven
- Gas burners
- Nozzle mix burners
- Premix burners (may require additional equipment)

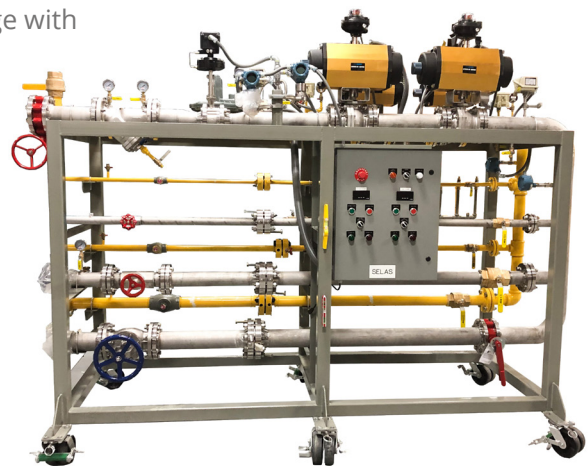

Example of a customizable fuel train.



Diverse Combustion Technologies. One Reliable Source.

Standard Fuel Train Specs

P/N	GT-06R-S-P-X-HB-X	GT-08R-S-P-X-HB-X	GT-12R-S-P-X-HB-X	GT-16R-S-P-X-HB-X	GT-20R-S-P-X-HB-X	GT-24R-S-P-X-HB-X
Size	3/4"	1"	1-1/2"	2"	2-1/2"	3"
Natural gas flow rate (mbtu/hr)	1000	1900	4000	7300	12000	17000
Max Inlet Pressure rating	7 psi	7 psi	7 psi	7 psi	7 psi	7 psi
Minimum pressure (above target outlet pressure at max flow)	1 psi	1 psi	1 psi	1 psi	1 psi	1 psi
Outlet pressure (both springs included)	7-30" WC Orange	7-30" WC Orange	7-30" WC Orange	7-30" WC Orange	7-30" WC Orange	7-30" WC Orange
	2-8" WC Red	2-8" WC Red	2-8" WC Red	2-8" WC Red	2-8" WC Red	2-8" WC Red
Overall length (center of upright pipe to end)	52"	56"	64"	68"	74"	84"
Overall length (end to end)	53"	57"	65"	69"	76"	86-1/2"
Height	18-3/4"	19-1/8"	19-3/4"	20-1/2"	24-5/8"	25-7/8"
Width	9-1/2"	10-1/4"	11-3/4"	11-3/4"	14"	14"

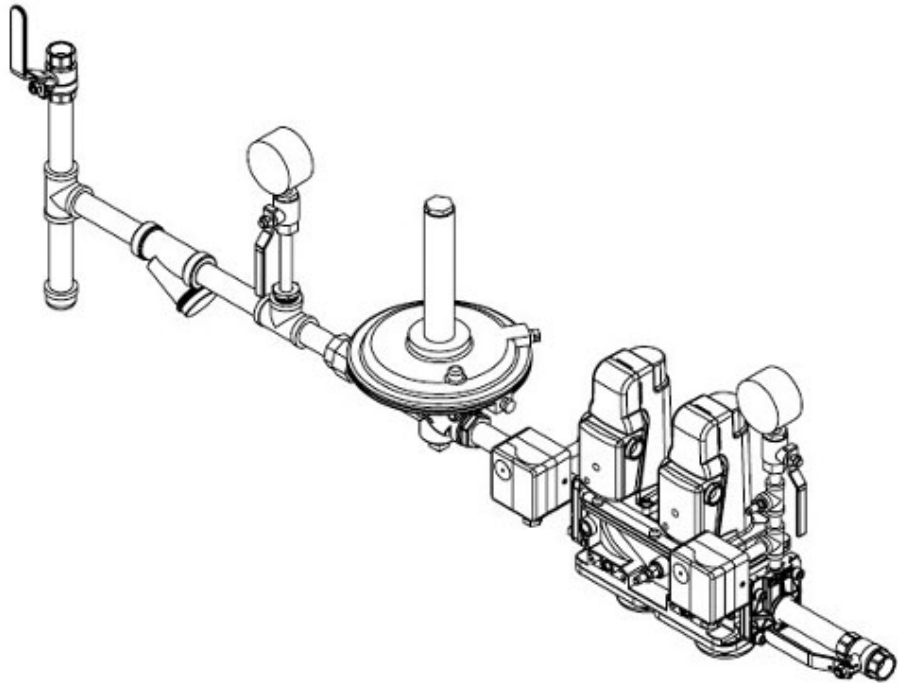

11012 Aurora Hudson Rd • Streetsboro, OH 44241
1-800-523-6500 • sales@selas.com
www.selas.com